

Valvola OVERCENTER semplice effetto compensata in pressione con pilotaggio esterno flangiabile
Flange mounted single effect pressure compensated COUNTERBALANCE valve with external pilot

mod. OVC-SE-CC-F2-34

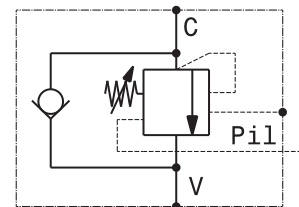
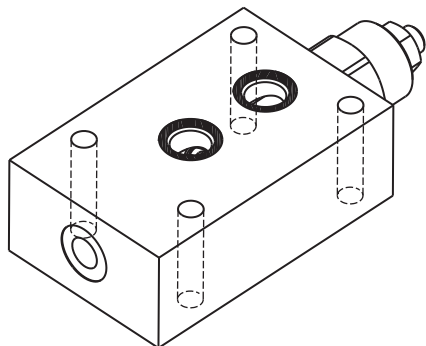

Corpo in alluminio
 Aluminium body

Pressione massima <i>Max pressure</i>	350 bar <i>5000 psi</i>
Rapporto di pilotaggio standard <i>Standard pilot ratio</i>	4:1
Rapporto di pilotaggio a richiesta <i>Pilot ratio upon request</i>	3:1 8:1 10:1

Dati e tarature ottenuti usando olio con viscosità 30 cSt a 50°C
Performances and calibrations are carried out by using hydraulic oil with 30 cSt viscosity at 50°C

Viscosità consigliate <i>Recommended viscosity</i>	10 ÷ 420 cSt
Temperature di lavoro <i>Working temperature</i>	-20 ÷ +90 °C
Filtrazione assoluta <i>Absolute filtration</i>	25 µ

Modello <i>Type</i>	V, C	Pil	Portata max <i>Max. flow</i>
OVC-SE-CC-F2-34	Ø 14	1/4" GAS	100 l/min 26 gpm

Taratura <i>Setting</i>	La valvola deve essere tarata almeno 1.3 volte la massima pressione indotta dal carico <i>The valve must be set at least 1.3 times maximum load induced pressure</i>		
Codice <i>Code</i>	Taratura standard <i>Standard setting</i> (Q=5 l/min)	Campo di taratura <i>Adj. Pressure range</i>	Colore molla <i>Spring color</i>
01	100 bar <i>1450 psi</i>	20+200 bar <i>290+2900 psi</i>	Bianco <i>White</i>
02	280 bar <i>4000 psi</i>	50+350 bar <i>725+5000 psi</i>	Nero <i>Black</i>

Regolazioni - Adjustments

Vite esterna esagono incassato <i>Leakproof hex socket screw</i>	Piombatura <i>Sealing cap</i>	Cappello <i>Cap</i>
---	----------------------------------	------------------------

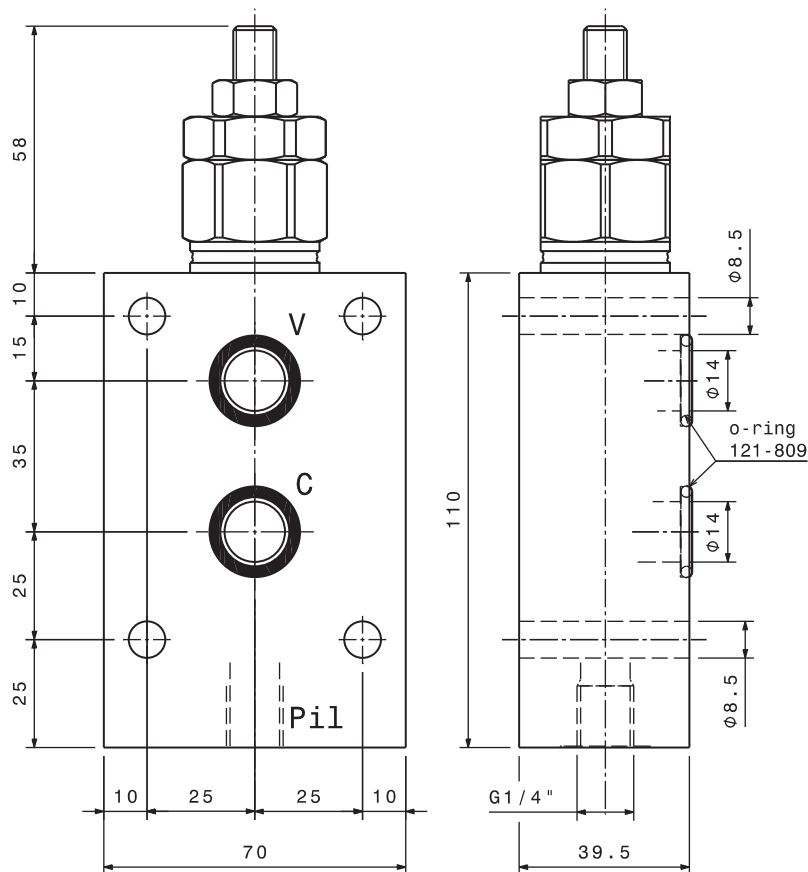

Sigla di ordinazione / Ordering code

OVC-SE-CC-F2-34 — 02 — -

Modello <i>Type</i>	Codice taratura <i>Setting code</i> 01, 02	Codice regolazione <i>Adjustment code</i> -, C, D
------------------------	--	---

For flow diagram see
 PRESSURE DROP OVERCENTER VALVES (13)

I dati non sono impegnativi, CBF si riserva di apportare modifiche senza preavviso.
The specifications are not binding, CBF reserves the right to introduce modifications without notice.