

Divisore – riunificatore di flusso a cartuccia
Flow divider combiner – cartridge type
mod. DFR-12-C

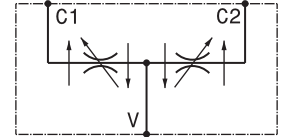
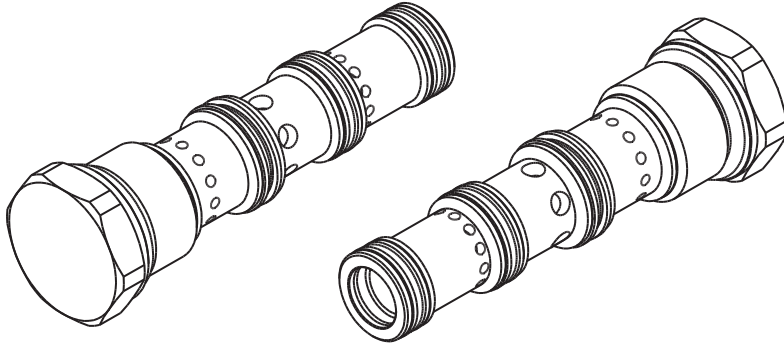

Portata massima Max flow	70 l/min 18.5 gpm
Pressione massima Max pressure	350 bar 5000 psi
Coppia di serraggio Installation torque	80 ÷ 100 Nm 60 ÷ 75 lbf ft
Errore max di divisione Flow accuracy of inlet flow	± 3%

Dati e tarature ottenuti usando olio con viscosità 30 cSt a 50°C Performances and calibrations are carried out by using hydraulic oil with 30 cSt viscosity at 50°C	
Viscosità consigliate Recommended viscosity	10 ÷ 420 cSt
Temperature di lavoro Working temperature	-20 ÷ +90 °C
Filtrazione assoluta Absolute filtration	25 µ

Codice Code	Campo di portata Flow range
01	3 ÷ 6 l/min 0.8 ÷ 1.6 gpm
02	7 ÷ 12 l/min 1.8 ÷ 3.2 gpm
03	13 ÷ 25 l/min 3.4 ÷ 6.6 gpm
04	26 ÷ 40 l/min 6.9 ÷ 10.5 gpm
05	40 ÷ 70 l/min 10.5 ÷ 18.5 gpm

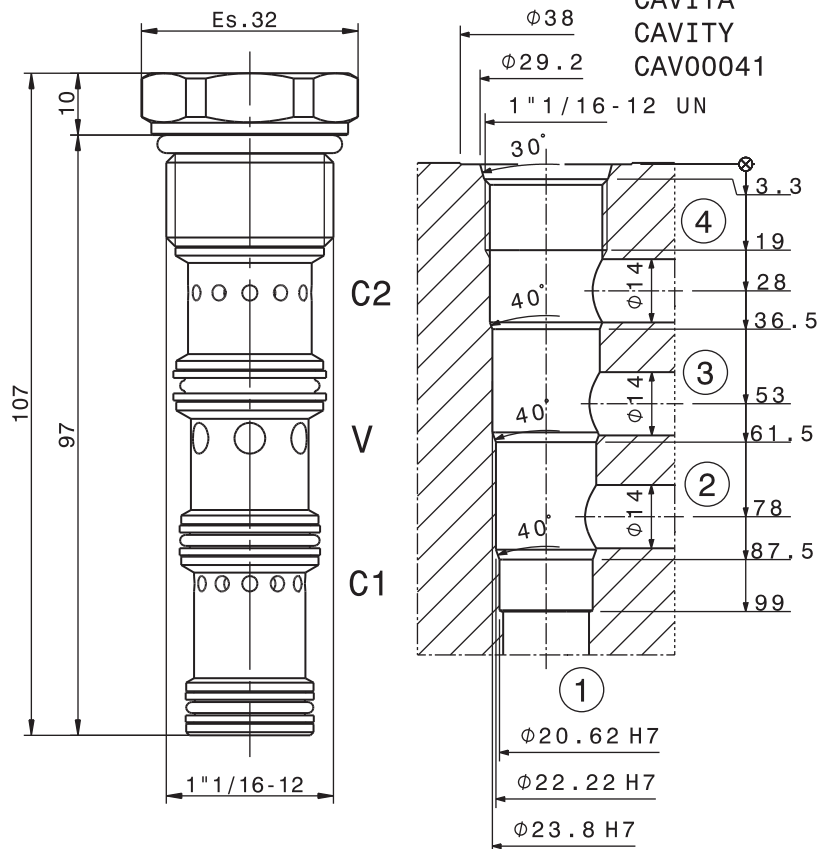

Sigla di ordinazione / Ordering code

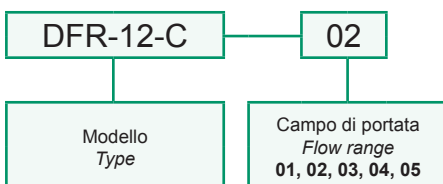

I dati non sono impegnativi, **CBF** si riserva di apportare modifiche senza preavviso.
The specifications are not binding, **CBF** reserves the right to introduce modifications without notice.