

Divisore – riunificatore di flusso a cartuccia
Flow divider combiner – cartridge type
mod. DFR-20-C

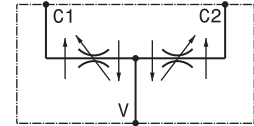
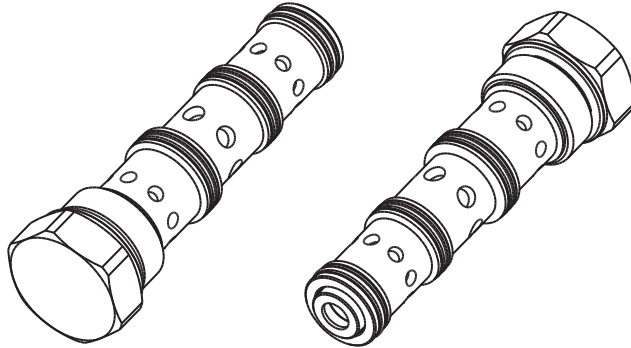

Portata massima Max flow	250 l/min 66 gpm
Pressione massima Max pressure	350 bar 5000 psi
Coppia di serraggio Installation torque	240 ÷ 260 Nm 180 ÷ 195 lbf ft
Errore max di divisione Flow accuracy of inlet flow	± 3%

Dati e tarature ottenuti usando olio con viscosità 30 cSt a 50°C
Performances and calibrations are carried out by using hydraulic oil with 30 cSt viscosity at 50°C

Viscosità consigliate Recommended viscosity	10 ÷ 420 cSt
Temperature di lavoro Working temperature	-20 ÷ +90 °C
Filtrazione assoluta Absolute filtration	25 µ

Codice Code	Campo di portata Flow range
01	40 ÷ 70 l/min 10.5 ÷ 18.5 gpm
02	60 ÷ 100 l/min 16 ÷ 26 gpm
03	90 ÷ 140 l/min 24 ÷ 37 gpm
04	120 ÷ 200 l/min 32 ÷ 53 gpm
05	150 ÷ 250 l/min 40 ÷ 66 gpm

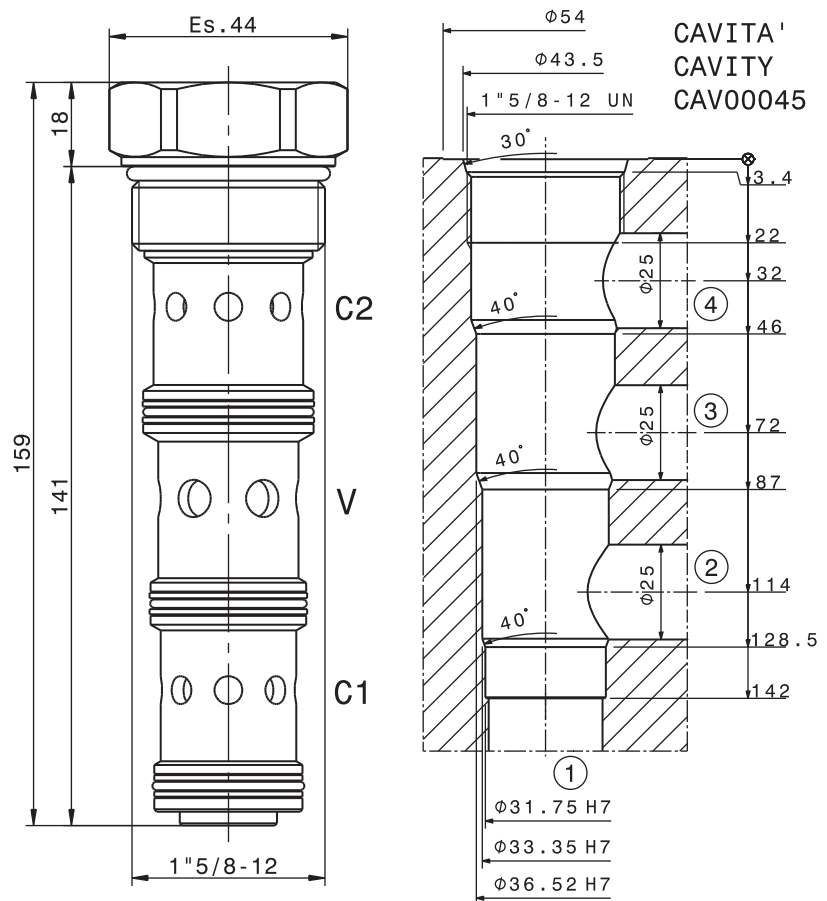

Sigla di ordinazione / Ordering code

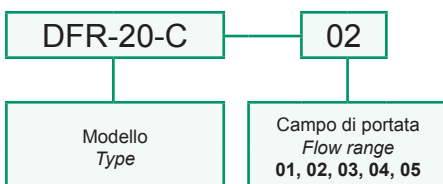

I dati non sono impegnativi, **CBF** si riserva di apportare modifiche senza preavviso.
The specifications are not binding, **CBF** reserves the right to introduce modifications without notice.