

Valvola OVERCENTER doppio effetto a cartuccia con sblocco freno flangiabile su motori DANFOSS-OMP-OMPL-OMR
Double effect cartridge OVERCENTER valve with brake unclamping, flangeable to DANFOSS OMP-OMPL-OMR motors

mod. OVC-DE-FMD-SF-C-12

Corpo in alluminio

Aluminium body

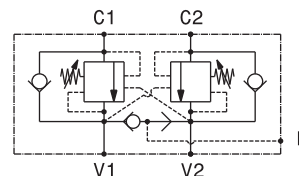
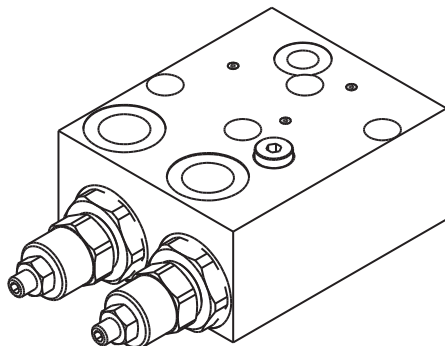

Portata massima Max flow	60 l/min 16 gpm
Pressione massima Max pressure	350 bar 5000 psi
Rapporto di pilotaggio standard Standard pilot ratio	4,25:1
Rapporto di pilotaggio a richiesta Pilot ratio upon request	3:1 8:1 10:1

Taratura Setting	La valvola deve essere tarata almeno 1.3 volte la massima pressione indotta dal carico The valve must be set at least 1.3 times maximum load induced pressure			
	Codice Code	Taratura standard Standard setting (Q=5 l/min)	Campo di taratura Adj. Pressure range	Colore molla Spring color
	01	100 bar 1450 psi	20+200 bar 290+2900 psi	Bianco White
	02	280 bar 4000 psi	50+350 bar 725+5000 psi	Nero Black

Regolazioni Adjustments

- Vite esterna esagono incassato Leakproof hex socket screw	C Piombatore Sealing cap	D Cappellotto Cap
---	--------------------------------	-------------------------

Dati e tarature ottenuti usando olio con viscosità 30 cSt a 50°C Performances and calibrations are carried out by using hydraulic oil with 30 cSt viscosity at 50°C	
Viscosità consigliate Recommended viscosity	10 ÷ 420 cSt
Temperature di lavoro Working temperature	-20 ÷ +90 °C
Filtrazione assoluta Absolute filtration	25 µ

Sigla di ordinazione / Ordering code

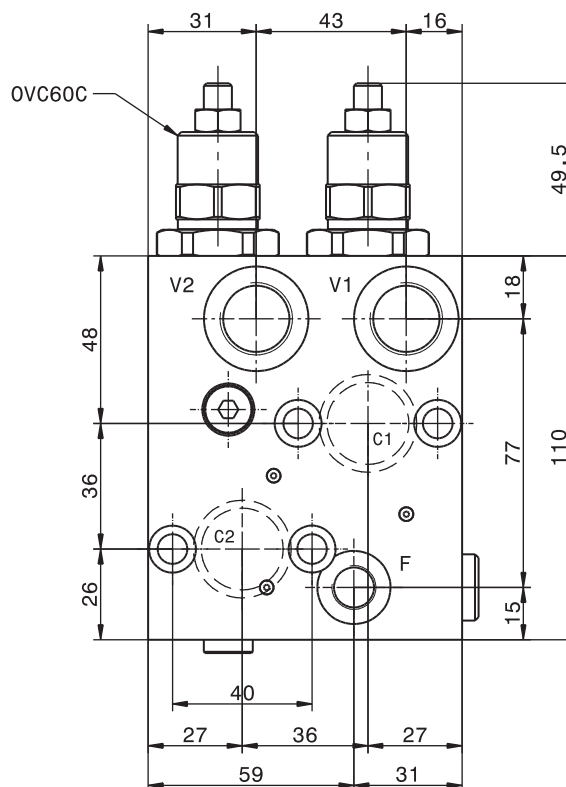
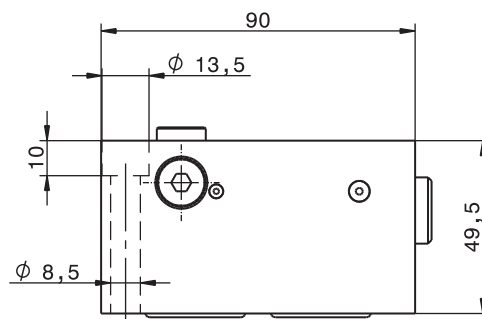
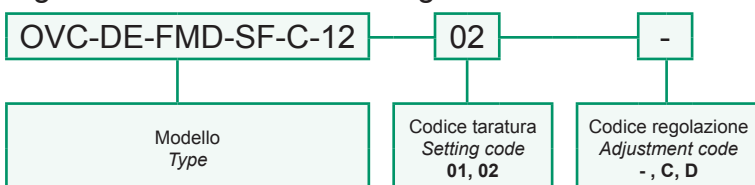

I dati non sono impegnativi, CBF si riserva di apportare modifiche senza preavviso.
The specifications are not binding, CBF reserves the right to introduce modifications without notice.